

Installation Instructions

Instrucciones de instalación, Instructions d'installation, Installationsanleitung, إرشادات التركيب,
 Installatie-instructies, Instruções de instalação, Installatie-instructies,
 設置手順説明, Οδηγίες εγκατάστασης

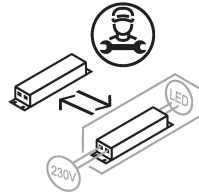

Product Code:[AGAB_/1]



Master
Translations
QR Link

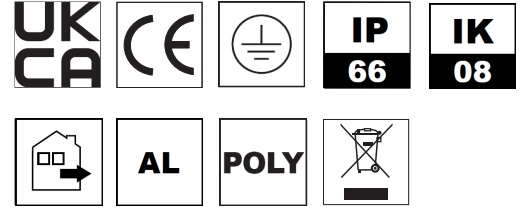

Product dimension(mm)

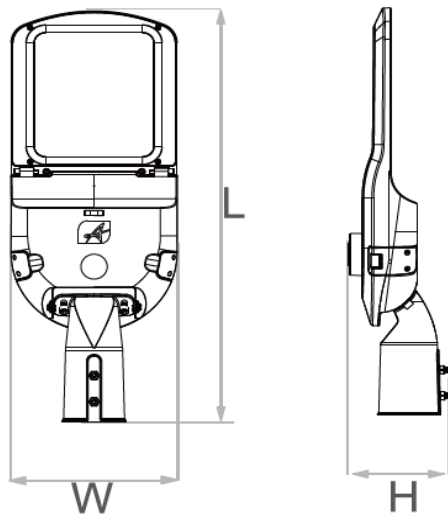

Gabbro 1	
20W/40W/60W	
Lamp L	583.6mm
W	200.0mm
H	145.1mm
Gabbro 2	
80W/100W	
Lamp L	627.7mm
W	240.0mm
H	144.6mm

Side Arm Installation

1

Use either the blank cap or a sensor with Nema socket
 If PC version is being used, remove blank cap, twist & lock into place.

PC: AGAB/PC/1

2

M8/22Nm

Loosen the screws to adjust the angle of the fitting

3

Once adjusted to the desired angle, tighten the screws
 Fixed positions at 5 degree Increments

Built in spirit level on underside for assistance with column level

Ansell Electrical Products
 Unit 6B, Stonecross Industrial Park,
 Yew Tree Way,
 Warrington,
 WA3 3JD

Ansell (Sales & Distribution)
 Unit 2, M2 Business Park,
 Duncrue Street,
 Belfast,
 BT3 9AQ

Ansell (Sales & Distribution) Republic of Ireland Limited
 Unit G1, Block G,
 Calmount Park, Calmount Avenue
 Dublin 12,
 D12 TH56

www.ansell-lighting.com

Post Top Installation

1

Remove the screws to rotate the spigot to desired position

2

M8/22Nm

Loosen the screws to adjust the angle of the fitting

3

Once adjusted to the desired angle, tighten the screws

Fixed positions at 5 degree Increments

Built in spirit level on underside for assistance with column leveling

M8/22Nm

Spigot Size: 76mm
60mm spigot adapter: AGAB/SB7/1

Brown:L
Blue:N
Yellow and green: ⚡

AC Rubber cable - 3x1.0mm² - 0.65m

Note: You must disconnect the power supply before you attempt to adjust the colour temperature

OPEN

AGAB1/1		AGAB2/1		CCT switch	
Position	Power	Position	Power	Position	Color Temperature
Left	20W	Left	80W	Left	3000k
Middle	40W	Right	100W	Middle	4000k
Right	60W			Right	5000k